

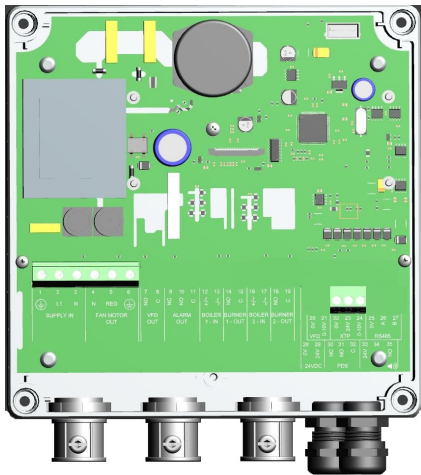





EBC24X

Motor power relay



READ AND SAVE THESE INSTRUCTIONS!

	Product information	Chapters 1 + 2
	Mechanical installation	Chapter 3
	Electrical installation	Chapter 4
	Start up and configuration	Chapter 5
	Maintenance and troubleshooting	Chapter 6

Job name: _____

Installer: _____

Installation date: _____

Manufacturer contact information:
exodraft a/s • Tel: +45 7010 2234
info@exodraft.dk • www.exodraft.com



Contents

1. Product information	
1.1 Function	3
1.2 Shipping	3
1.3 Warranty	3
2. Specifications	
2.1 Dimensions and capacities	4
3. Mechanical installation	
3.1 Location	5
3.2 Mounting of motor power relay	5
4. Electrical installation	
4.1 General	6
4.2 Connecting to an EBC12, EBC14 or MEC18	7
4.3 Connecting to an EBC30/EBC31	8
4.4 Connecting multiple EBC24X controls	9
5. Start up and configuration	
5.1 General	10
6. Maintenance and troubleshooting	
6.1 General	11
Notes	12

Symbol legend

The following terms are used throughout this manual to bring attention to the presence of potential hazards or to important information concerning the product.



DANGER

Indicates an imminent hazardous situation which, if not avoided, will result in death, serious injury or substantial property damage.



CAUTION

Indicates an imminent hazardous situation which, if not avoided, may result in personal injury or property damage.



TO REDUCE THE RISK OF FIRE, ELECTRICAL SHOCK OR INJURY TO PERSONS, OBSERVE THE FOLLOWING:

1. Use this unit in the manner intended by the manufacturer. If you have questions, contact the manufacturer at the address or telephone number listed on the front of the manual.
2. Before servicing or cleaning the unit, switch off at service panel and lock service panel to prevent power from being switched on accidentally.
3. Installation work and electrical wiring must be done by a qualified person(s) in accordance with applicable codes and standards.
4. Follow the appliance manufacturer's guidelines and safety

standards and the national authorities safety standards in the country in which the installation is taking place.

5. This unit must be grounded.

How to use this manual

This installation manual does not contain any system design documentation. System design documentation is available from **exodraft**.

Accessories and variable frequency drives are not covered by this manual. Please refer to these component's individual manuals.

1. Product information

1.1 Function

Use The **exodraft** EBC24X motor power relay is used in conjunction with an **exodraft** control panel to operate multiple single-phase intake or exhaust fans. The **exodraft** main control will regulate the fan functions while the EBC24X acts as an external motor speed control. The main control powers each EBC24X through a 0-10 VDC signal.

Controls compatible with the EBC24X are: BDC8, EBC12, EBC14, EBC24, MEC18, MEC24, EBC30 and EBC31.

The EBC24X allows the main control to handle multiple single-phase RSV fans by increasing the system' motor load capacity. One RSV fan is connected to the main control while additional fans are connected to one or more EBC24X's.

The features of the main control panel apply to each EBC24X connected. The main control will regulate the speed of all fans in use.

The EBC24X housing is NEMA 3R rated polycarbonate.

All terminals have a LED for fail-safe supervision and easy troubleshooting.

Listings Listed to UL 60947-4-1 and CSA C22.2 No. 14-10 Standard for Industrial Control Equipment .

1.2 Shipping

Standard packing list

The EBC24X contains the following:

- The EBC24X control box

If other components are shipped, these will appear on the shipment packing list.

1.3 Warranty

Complete warranty conditions are available from exodraft.

2. Specifications

4

2.1 Dimensions and capacities

EBC24X control		
Power supply	V	1 x 120 V AC
Amperage	A	6.3
Operating temperature	°F/°C	-4 to 122/-20 to 50
Dimensions	A in/mm	6.9/175
	B in/mm	6.9/175
	C in/mm	4.33/110
Weight	lbs/kg	2.8/1.3

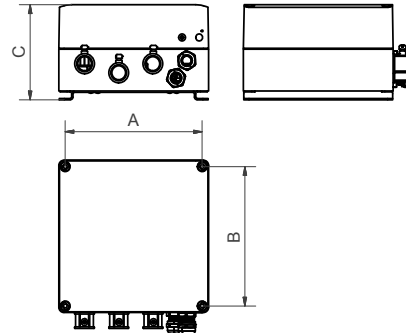

One or more **exodraft** fan(s) can be connected to each EBC24X in use depending on the current draw of the fan motor. The table below displays the number of each fan that can be connected to a single EBC24X as well as the current draw of the fan(s).

Fan model (single phase motor)	BESF 146 RSIF 146	RSV 200	RSV 250 BESF 160 RSIF 160	BESB 250 RSIB 300	RSV 315 BESF 180 RSIF 180
# per EBC24X	5	4	2		1
Amperage draw per fan	1.2	1.4	2.9		5.8
Total amperage draw	6.0	5.6	5.8		5.8

3. Mechanical installation

3.1 Location

The **exodraft** motor power relay EBC24X must be installed inside, preferably in the boiler room. The control does not need to be installed in an enclosure. For ease of installation, it should be installed close to the main EBC control.

3.2 Mounting of motor power relay

The EBC24X motor power relay can be mounted directly on a wall or similar. Remove the clear cover. The mounting holes are located under the plastic screws that hold the cover in place.

See figure below for mounting hole-pattern.

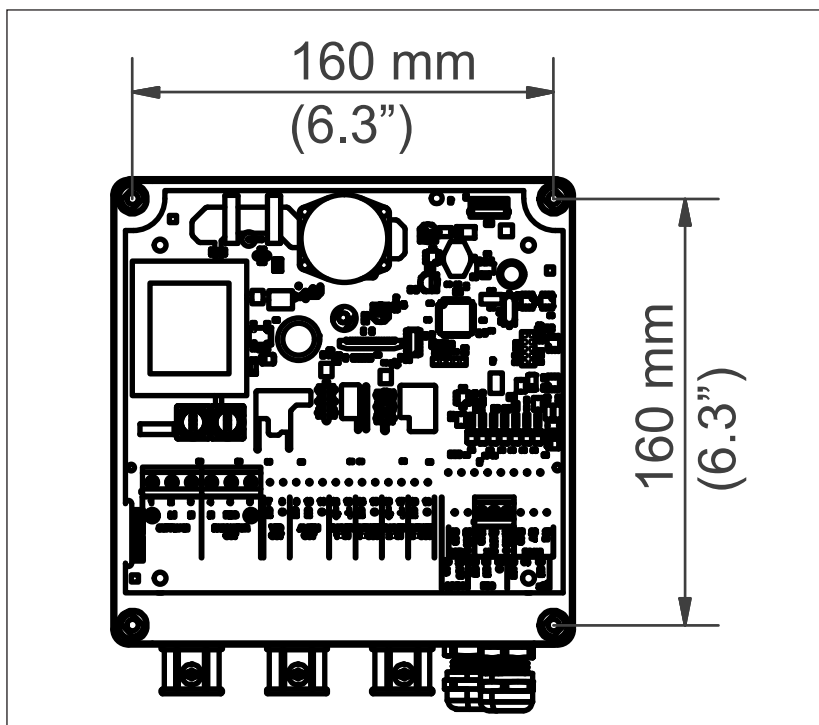

Fig. 1

4. Electrical installation

6

4.1 General



DANGER

Turn off electrical power before servicing. Contact with live electric components can cause shock or death.



NOTE

EBC24 is designed for 1x120 VAC power supply only. Fan output is regulating on the phase side and cannot be connected to other circuits.

The figure below shows a general connection diagram.

The EBC24 shown in the diagram is representative of any compatible **exodraft** control.

The designations for each terminal on the control board are shown below.

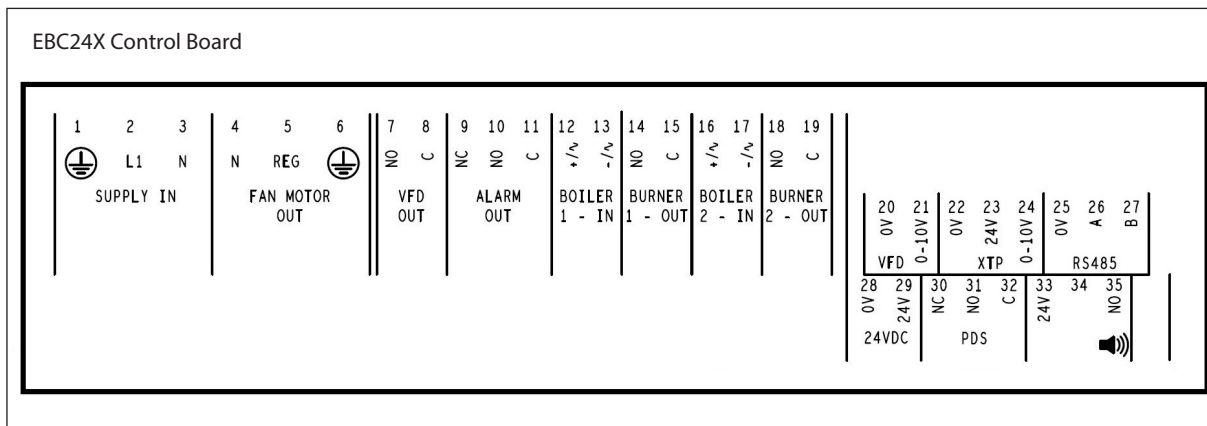

Fig. 2

Terminal	Use
1	Power supply – Grund (PE)
2	Power supply – L1
3	Power supply – N
4	Chimney fan – N
5	Chimney fan – Regulating phase
6	Chimney fan – ground (PE)
22	Control signal for exodraft main control (0 V DC)
24	Control signal for exodraft main control (10 V DC)

4.2 Connecting to an EBC12, EBC14 or MEC18

Below is the wiring diagram connecting an EBC24X to EBC24 or MEC24

To wire the main control to an EBC24X, shielded wire should be connected to terminals 20 and 21 of the main control and run to terminals 22 and 24, respectively, on the EBC24X.

NOTE: Terminal 4 on the circuit boards is always hot (120 V AC). Terminal 5 (Line) regulates the fan speed.

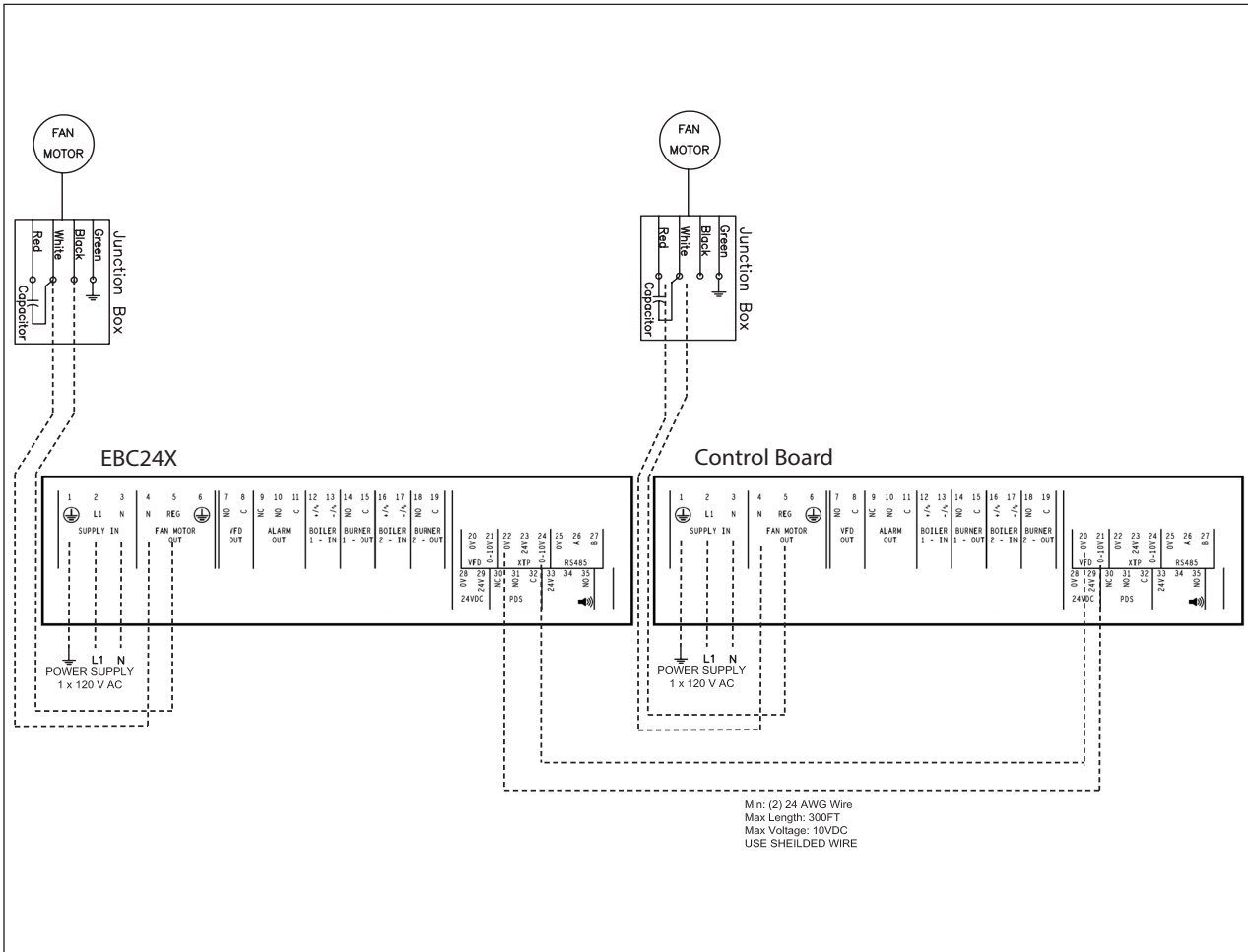

4.3 Connecting to an EBC30/EBC31

The terminal connections of the EBC30/EBC31 and EBC24X depend on the function of the fans connected to the EBC24X.

For exhaust fans, connect terminals 38 and 37 of the EBC 30 to terminals 22 and 24, respectively, to the EBC24X.

For intake fans, use shielded wire to connect terminals 46 and 45 of the EBC30/EBC31 to terminals 22 and 24, respectively, to the EBC24X.

The diagram below shows the connection of an exhaust fan to an EBC24X. A similar set-up can be used for applications requiring the intake fan to be connected to the EBC24X. When controlling both intake and exhaust fans with the EBC30/EBC31, a Triac Board Add-On is used.

See the EBC30/EBC31 manual for further information.

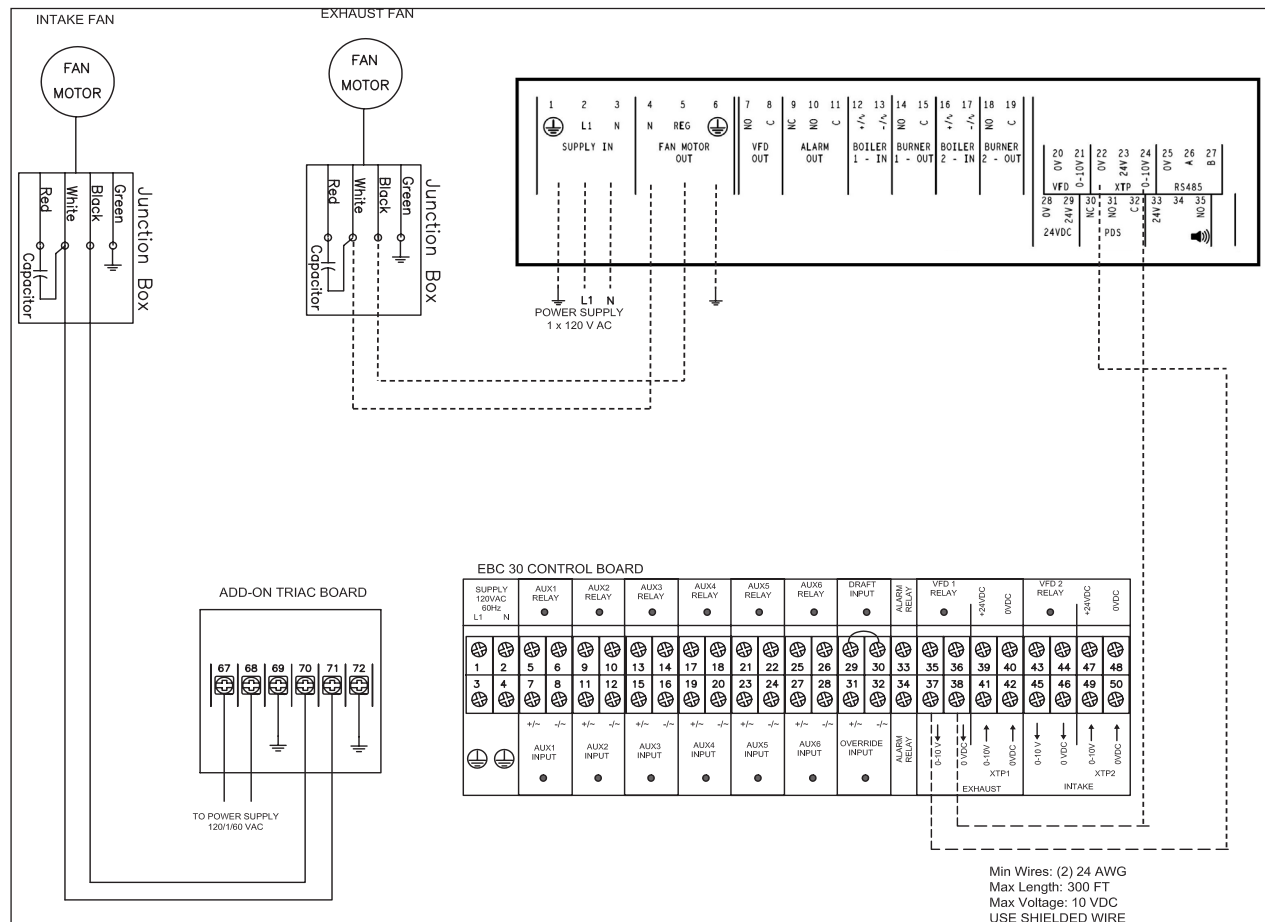

4.4 Connecting multiple EBC24X controls

More than one (1) EBC24X can be used in a system. To connect multiple EBC24X's, wire the main control to the first EBC24X as shown in sections 4.2 and 4.3.

Next, run shielded wire from terminal 22 of the first EBC24X to terminal 22 of the next one. The same should be done with wire running from terminal 24.

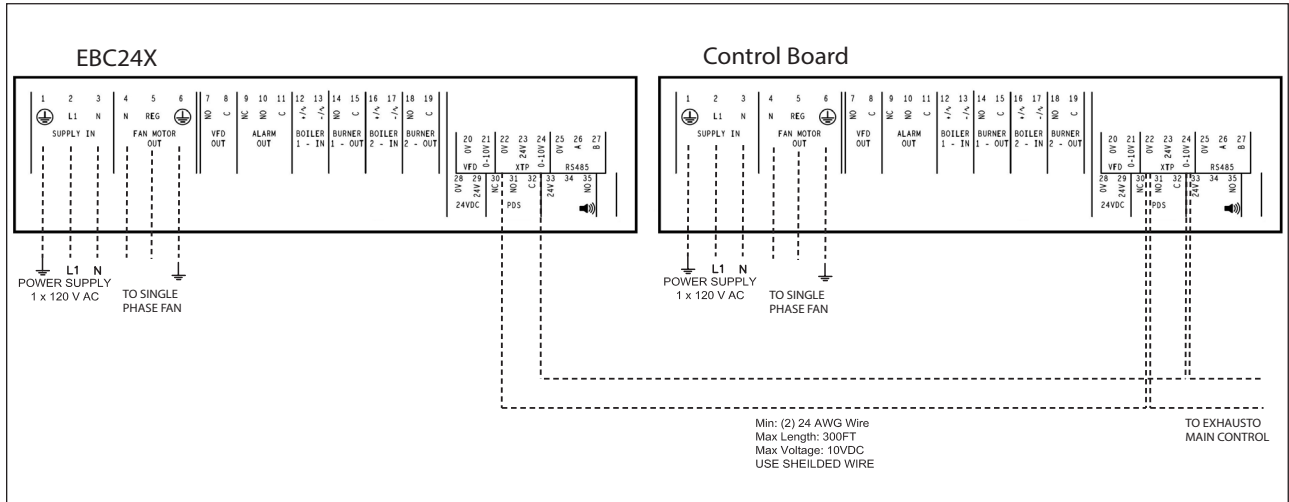



5. Start up and configuration

10

5.1 General

The dip switch settings used on the main control (BDC8, EBC12, EBC14, EBC30 or MEC18) will apply to each EBC24X in operation. For additional reference on setting the dip switches, refer to manual of the main control.

Set the draft set point on the main control in accordance with the operation manual. Once this is set, all fans connected to the control system will run at the same speed.



6. Maintenance and troubleshooting

6.1 General

For additional troubleshooting, refer to the manual of the main control (BDC8, EBC12, EBC14, MEC18, EBC24, MEC24, EBC30 or EBC31).

Observation	Problem	Solution
Fan(s) connected to the EBC24X do not increase speed.	Wiring of terminals 22 & 24 on EBC24X.	Make sure wires are connected properly to correct terminals.
One or more LED's on EBC24X('s) are not lit.	1. Faulty wiring. 2. Bad power supply.	1. Check wiring between control and EBC24X. 2. Check power supply.

Notes

Lined area for notes, consisting of numerous horizontal lines.